

High performance trucks with optimum energy efficiency

Application-specific truck performance packages with Efficiency and Drive & Lift Plus performance models

Parameter steering (optional)

Lateral battery replacement with SnapFit

Quickly and intuitively adaptable operator cab

Operator-oriented storage design



EFG 540k/540/545k/545/550/S40/S50

Electric four wheel truck (4,000/4,500/4,990/5,000 kg)

Our Pure Energy technology concept enables us to achieve the best possible energy efficiency coupled with maximum performance.

By using the most advanced three-phase AC technology in combination with our own manufactured electronic controller as well as the compact hydraulic unit, we have been able to significantly reduce energy consumption – while simultaneously increasing throughput. This is verified by tests using the VDI cycle: At full throughput, our new Series 5 EFG consumes up to 20% less energy than a comparable competitors model.

A choice of configuration packages with variable travel/lift speeds called Efficiency and Drive&Lift Plus will complete your transport and stacking operations with maximum energy efficiency.

The infinitely adjustable steering column and armrest allow for adjustment to suit all operator sizes. The individual adjustment of the controls is very easy to carry out thanks to the single-point adjustment via two adjustable axes.

The truck chassis is closed on the right side of the operator. This guarantees maximum rigidity and stability for the overall design. It also forms the basis for a number of storage options: From two sizes of cup holders a clipboard to various sizes of compartments for e.g. papers and phone. There is therefore room for everything which operators need to work efficiently throughout their shifts.

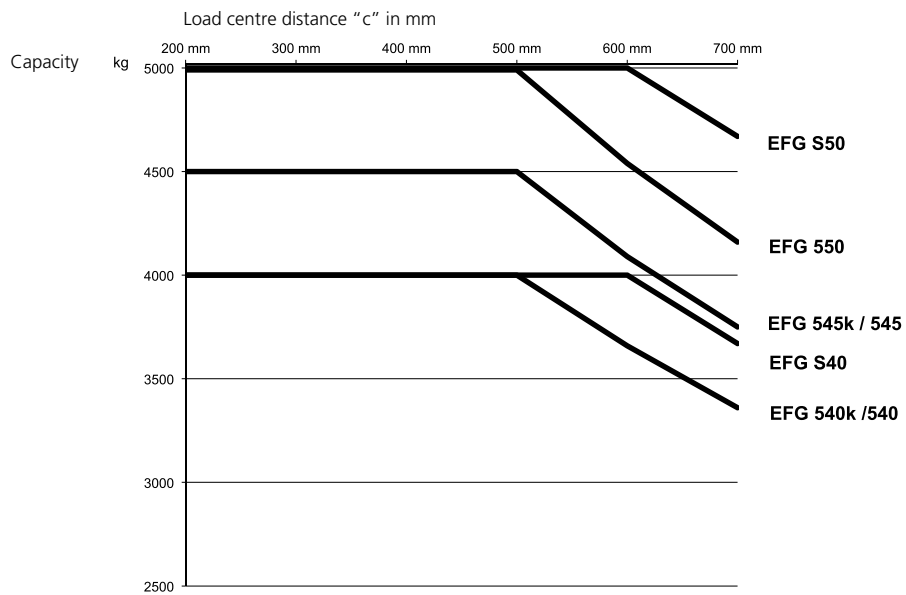
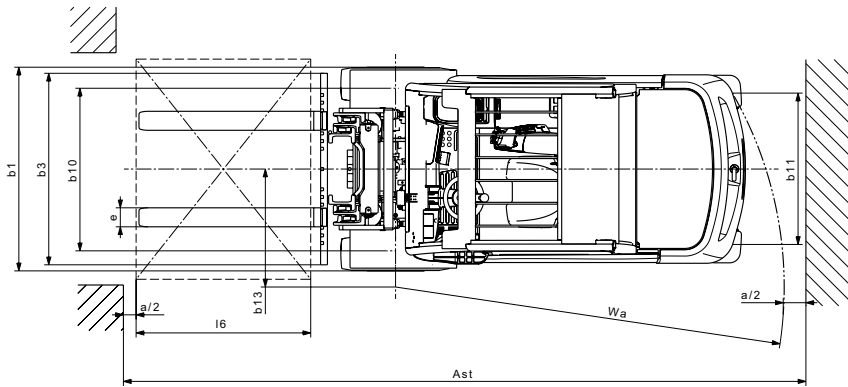
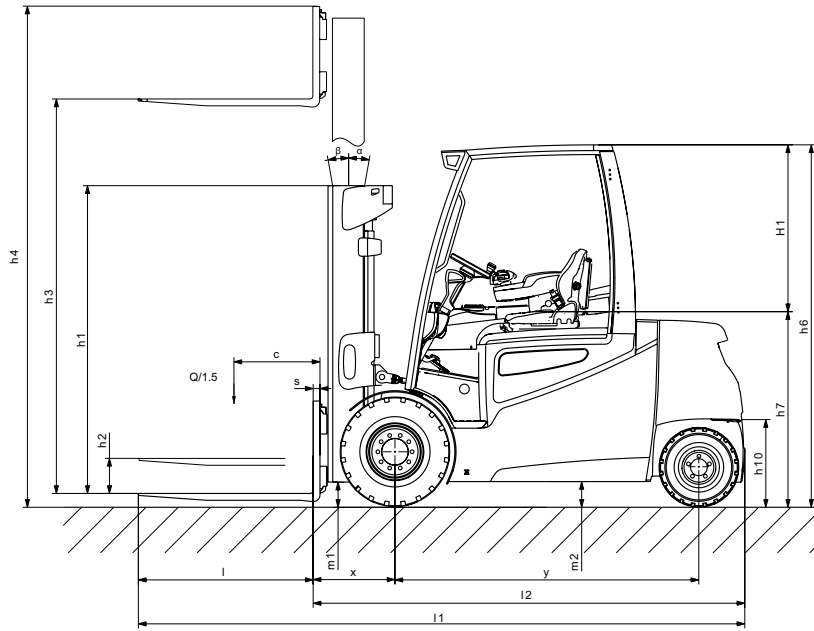

EFG 540k/540/545k/545/550/S40/S50

Standard mast types EFG 540k/540/545k/545/550/S40/S50													Capacity chart (kg)				
	Lift h3 (mm)	Lowered mast height h1 (mm)		Free lift h2 (mm)			Extended mast height h4 (mm)				Tilt of mast/ fork carriage forward/back- ward α/β (°)		no side-shift, tyres are simply solid				
													c=500		c=600		
		EFG 540k / 540 / 545k / 545 / 550 / S40	EFG S50	EFG 540k / 540 / 545k / 545	EFG 550 / S40	EFG S50	EFG 540k / 540	EFG 545k / 545	EFG 550 / S40	EFG S50	EFG 540k / 540 / 545k / 545 / 550 / S40	EFG S50	EFG 540k / 540	EFG 545k / 545	EFG S50	EFG S40	EFG S50
Zwei- fach ZT	2750	2125	2125	150	150	150	3425	3410	3560	3575	6/8	6/8	4000	4500	4990	4000	5000
	3000	2250	2250	150	150	150	3675	3660	3810	3825	6/8	6/8	4000	4500	4990	4000	5000
	3500	2500	2500	150	150	150	4175	4160	4310	4325	6/8	6/8	4000	4500	4990	4000	5000
	4000	2750	2750	150	150	150	4675	4660	4810	4825	6/8	6/8	4000	4500	4990	4000	5000
	4500	3000	3000	150	150	150	5175	5160	5310	5325	6/8	6/8	4000	4500	4990	4000	5000
	5000	3250	3250	150	150	150	5675	5660	5810	5825	6/8	6/8	4000	4500	4900	4000	5000
	5500	3500	3500	150	150	150	6175	6160	6310	6325	6/5	6/5	3850	4100	4800	3850	n/a
	6000	3750	3750	150	150	150	6675	6660	6810	6825	6/5	6/5	3700	n/a	4600	3700	n/a
6500	4000	4000	150	150	150	7175	7160	7310	7325	6/5	6/5	n/a	n/a	n/a	n/a	n/a	
Zwei- fach ZZ	2725	-	2100	-	-	1225	-	-	-	3600	-	6/8	-	-	-	-	5000
	2775	2100	-	1380	1230	-	3495	3480	3630	-	6/8	-	4000	4500	4990	4000	-
	2975	-	2225	-	-	1350	-	-	-	3845	-	6/8	-	-	-	-	5000
	3025	2225	-	1505	1355	-	3745	3730	3880	-	6/8	-	4000	4500	4990	4000	-
	3475	-	2475	-	-	1600	-	-	-	4345	-	6/8	-	-	-	-	5000
	3525	2475	-	1755	1605	-	4245	4230	4380	-	6/8	-	4000	4500	4990	4000	-
	3975	-	2725	-	-	1850	-	-	-	4845	-	6/8	-	-	-	-	5000
	4025	2725	-	2005	1855	-	4745	4730	4880	-	6/8	-	4000	4500	4990	4000	-
	4475	-	2975	-	-	2100	-	-	-	5345	-	6/8	-	-	-	-	5000
	4525	2975	-	2255	2105	-	5245	5230	5380	-	6/8	-	4000	4500	4990	4000	-
	4975	-	3225	-	-	2350	-	-	-	5845	-	6/8	-	-	-	-	5000
	5025	3225	-	2505	2355	-	5745	5730	5880	-	6/8	-	n/a	n/a	n/a	n/a	-
	5475	-	3475	-	-	2600	-	-	-	6345	-	6/5	-	-	-	-	n/a
	5525	3475	-	2755	2605	-	6245	6230	6380	-	6/5	-	n/a	n/a	n/a	n/a	-
Drei- fach DZ	3930	-	2060	-	-	1185	-	-	-	4805	-	6/8	-	-	-	-	5000
	4050	-	2100	-	-	1225	-	-	-	4925	-	6/8	-	-	-	-	5000
	4150	2100	-	1380	1230	-	4870	4855	5005	-	6/8	-	4000	4500	4990	4000	-
	4425	-	2225	-	-	1350	-	-	-	5295	-	6/8	-	-	-	-	5000
	4855	2335	-	1615	1465	-	5575	5560	5710	-	6/8	-	3920	4420	4990	3920	-
	5175	-	2475	-	-	1600	-	-	-	6045	-	6/5	-	-	-	-	5000
	5275	2475	-	1755	1605	-	5995	5980	6130	-	6/5	-	3890	4300	4750	3890	-
	5550	-	2600	-	-	1725	-	-	-	6425	-	6/5	-	-	-	-	n/a
	5650	2600	-	1880	1730	-	6370	6355	6505	-	6/5	-	3750	4200	4610	3750	-
	5925	-	2725	-	-	1850	-	-	-	6795	-	6/5	-	-	-	-	n/a
	6200	-	2815	-	-	1940	-	-	-	7075	-	6/5	-	-	-	-	n/a
	6400	2850	-	2130	1980	-	7120	7105	7255	-	6/3	-	3550	4000	4300	3550	-
	6675	-	2975	-	-	2100	-	-	-	7545	-	6/5	-	-	-	-	n/a
	7180	3110	-	2390	2240	-	7900	7885	8035	-	6/3	-	3200	3200	4000	3200	-

Technical data in line with VDI 2198

		Jungheinrich					
		EFG 540k	EFG 540	EFG 545k			
Identification	1.1	Manufacturer (short form)					
	1.2	Model					
	1.3	Drive		Electric			
	1.4	Manual, pedestrian, stand-on, seated, order picker operation		Seat			
	1.5	Load capacity/rated load	Q t	4	4	4,5	
	1.6	Load centre distance	c mm	500			
	1.8	Load distance	x mm	510 ¹⁾			
	1.9	wheelbase	y mm	1856	2000	1856	
	Weights	2.1.1	Net weight incl. battery (see row 6.5)		kg	6726	6701
2.2		Axle load, w. load, front / rear		kg	9730 / 996	9726 / 975	10608 / 1078
2.3		Axle load, w.o. load, front / rear		kg	3553 / 3173	3706 / 2995	3659 / 3527
Wheels / chassis	3.1	Tyres		SE			
	3.2	Tyre size, at front		mm	250-15	250-15	28x12.5-15
	3.3	Tyre size, at rear		mm	21 x 8-9		
	3.5	Wheels, number front/rear (x = driven wheels)		2x/2			
	3.6	Track width, front	b10 mm	1115	1115	1155	
	3.7	Track width, rear	b11 mm	950			
	Basic dimensions	4.1	Tilt of mast/fork carriage forward/backward		α/β °	6/8	
4.2		mast height (lowered)		h1 mm	2250	2250	2236
4.3		Free lift		h2 mm	150		
4.4		Lift		h3 mm	3000		
4.5		Extended mast height		h4 mm	3675	3675	3660
4.7		Height of overhead guard		h6 mm	2365	2365	2350
4.8		Seat height/stand height		h7 mm	1224		
4.12		Coupling height		h10 mm	396		
4.12.1		2nd coupling height		mm	566		
4.19		total length with fork length 1150 mm		l1 mm	3808	3952	3808
4.20		Length incl. back of forks		l2 mm	2658	2802	2658
4.21		Total width		b1/b2 mm	1340	1340	1450
4.22		fork dimensions		s/e/l mm	50 / 125 / 1150	50 / 125 / 1150	50 / 150 / 1150
4.23		Fork carriage ISO 2328, class/type A, B		3A			
4.24		fork carriage width		b3 mm	1260		
4.31		floor clearance with load under mast		m1 mm	136	136	122
4.32		Floor clearance centre wheelbase		m2 mm	150		
4.33		Aisle width for pallets 1000 x 1200 sideways		Ast mm	3965	4160	3965
4.34	Aisle width for pallets 800 x 1200 lengthways		Ast mm	4165	4360	4165	
4.35	turning radius		Wa mm	2284	2450	2284	
4.36	Smallest pivot point distance		b13 mm	660	721	660	
Performance data	5.1	Travel speed, w. / w.o. load - Efficiency		km/h	14/ 16	14/ 16	14.0/ 15.5
		Travel speed, w. / w.o. load - Drive&Lift Plus		km/h	15 / 17	15 / 17	15 / 16.5
	5.2	Lift speed, w. / w.o. load - Efficiency		m/s	0.31/0.43	0.31/0.43	0.30/0.41
		Lift speed, w. / w.o. load - Drive&Lift Plus		m/s	0.35 / 0.5	0.35 / 0.5	0.33 / 0.45
	5.3	Lower speed, w. / w.o. load - Efficiency		m/s	0.54/0.46	0.54/0.46	0.52/0.47
		Lower speed, w. / w.o. load - Drive&Lift Plus		m/s	0.55 / 0.5		
	5.5	Drawbar pull w. / w.o. load - Efficiency		N	5100 / 5600	5100 / 5600	4900 / 5500
		Drawbar pull w. / w.o. load - Drive&Lift Plus		N	5100 / 5600	5100 / 5600	4900 / 5500
	5.6	Max. drawbar pull, laden/unladen - Efficiency		N	14600 / 14900	14600 / 14900	14500 / 14800
		Max. drawbar pull, laden/unladen - Drive&Lift Plus		N	14600 / 14900	14600 / 14900	14500 / 14800
	5.7	Gradeability w. / w.o. load - Efficiency		%	9.3/15.4	9.3/15.4	8.1/13.5
		Gradeability w. / w.o. load - Drive&Lift Plus		%	10.8 / 17.7	10.8 / 17.7	9.4 / 15.8
	5.8	Max. gradeability, laden/unladen - Efficiency		%	14.1/22.3	14.1/22.3	12.5/20.4
	Max. gradeability, laden/unladen - Drive&Lift Plus		%	15.4 / 26.1	15.4 / 26.1	13.7 / 23.9	
5.9	Acceleration time w. / w.o. load - Efficiency		S	5.2/ 4.4	5.2/ 4.4	5.7/ 4.8	
	Acceleration time w. / w.o. load - Drive&Lift Plus		S	5 / 4.4	5 / 4.4	5.5 / 4.8	
5.10	Service brake		Mechanical				
Electrics	6.1	Drive motor rating S2 60 min.		kW	14.5 / 18.0 ²⁾		
	6.2	Lift motor rating at S3 15%		kW	20.0 / 24.0 ²⁾		
	6.3	Battery according to DIN 43531/35/36 A,B,C, no		A 43536			
	6.4	Battery voltage/nominal capacity K5		V/Ah	80 / 775	80 / 930	80 / 775
	6.5	Battery weight		kg	1863	2178	1863
		Battery dimensions L/W/H		mm	1028 / 855 / 784	1028 / 999 / 784	1028 / 855 / 784
6.6	energy consumption according to VDI cycle		kW/h	11	11	12.1	
Misc..	8.1	type of drive control		Impuls/AC			
	8.2	working pressure for attachments		bar	200		
	8.3	oil flow for attachments		l/min	30		
	8.4	Sound pressure level at operator's ear according to EN 12053		dB (A)	69		
	8.5	Trailer coupling, model/type DIN		DIN 15170 H			

¹⁾ +31 mm with DZ mast

²⁾ Second value for Drive&Lift Plus package

In accordance with VDI Guideline 2198 this specification sheet provides details of the standard truck only. Non-standard tyres, different masts, optional equipment, etc. may result in different values.

Technical data in line with VDI 2198

		Jungheinrich					
		EFG 545	EFG 550	EFG S40	EFG S50		
Identification	1.1	Manufacturer (short form)					
	1.2	Model					
	1.3	Drive	Electric				
	1.4	Manual, pedestrian, stand-on, seated, order picker operation	Seat				
	1.5	Load capacity/rated load	Q t	4.5	4.99	4	5
	1.6	Load centre distance	c mm	500	500	600	600
	1.8	Load distance	x mm	510 ¹⁾			
	1.9	wheelbase	y mm	2000	2000	2080	2080
	Weights	2.1.1	Net weight incl. battery (see row 6.5)	kg	7161	7549	7176
2.2		Axle load, w. load, front / rear	kg	10549 / 1112	11282 / 1257	10025 / 1151	11677 / 1359
2.3		Axle load, w.o. load, front / rear	kg	3777 / 3385	3772 / 3777	3891 / 3285	3932 / 4104
Wheels / chassis	3.1	Tyres	SE				
	3.2	Tyre size, at front	mm	28x12.5-15	28 x 12.5-15	28x12.5-15	28 x 12.5-15
	3.3	Tyre size, at rear	mm	21 x 8-9	21 x 8-9	23x10-12	23x10-12
	3.5	Wheels, number front/rear (x = driven wheels)	2x/2				
	3.6	Track width, front	b10 mm	1155			
	3.7	Track width, rear	b11 mm	950	950	1200	1200
	Basic dimensions	4.1	Tilt of mast/fork carriage forward/backward	α/β °	6/8		
4.2		mast height (lowered)	h1 mm	2236			
4.3		Free lift	h2 mm	150			
4.4		Lift	h3 mm	3000			
4.5		Extended mast height	h4 mm	3660	3810	3810	3810
4.7		Height of overhead guard	h6 mm	2350			
4.8		Seat height/stand height	h7 mm	1224			
4.12		Coupling height	h10 mm	396			
4.12.1		2nd coupling height	mm	566			
4.19		total length with fork length 1150 mm	l1 mm	3962	3952	4072	4082
4.20		Length incl. back of forks	l2 mm	2802	2802	2922	2932
4.21		Total width	b1/b2 mm	1450			
4.22		fork dimensions	s/e/l mm	50 / 150 / 1150	50 / 150 / 1150	50 / 150 / 1150	60 / 150 / 1150
4.23		Fork carriage ISO 2328, class/type A, B		3A	3A	3A	4A
4.24		fork carriage width	b3 mm	1260			
4.31		floor clearance with load under mast	m1 mm	122			
4.32		Floor clearance centre wheelbase	m2 mm	150			
4.33		Aisle width for pallets 1000 x 1200 sideways	Ast mm	4160	4160	4379	4379
4.34		Aisle width for pallets 800 x 1200 lengthways	Ast mm	4360	4360	4579	4579
4.35	turning radius	Wa mm	2450	2450	2637	2637	
4.36	Smallest pivot point distance	b13 mm	721	721	673	673	
Performance data	5.1	Travel speed, w. / w.o. load - Efficiency	km/h	14.0/15.5	14.0/15.0	14.0/15.5	13.5/14.5
		Travel speed, w. / w.o. load - Drive&Lift Plus	km/h	15 / 16.6	15 / 16	15 / 16.6	14.5 / 15.5
	5.2	Lift speed, w. / w.o. load - Efficiency	m/s	0.30/0.41	0.28/0.41	0.30/0.41	0.27/0.40
		Lift speed, w. / w.o. load - Drive&Lift Plus	m/s	0.33 / 0.45	0.33 / 0.45	0.33 / 0.45	0.31 / 0.45
	5.3	Lower speed, w. / w.o. load - Efficiency	m/s	0.52/0.47			
		Lower speed, w. / w.o. load - Drive&Lift Plus	m/s	0.55 / 0.5			
	5.5	Drawbar pull w. / w.o. load - Efficiency	N	4900 / 5500	4800 / 5400	4900 / 5500	4700 / 5300
		Drawbar pull w. / w.o. load - Drive&Lift Plus	N	4900 / 5500	4800 / 5400	4900 / 5500	4700 / 5300
	5.6	Max. drawbar pull, laden/unladen - Efficiency	N	14500 / 14800	14400 / 14700	14500 / 14800	14400 / 14700
		Max. drawbar pull, laden/unladen - Drive&Lift Plus	N	14500 / 14800	14400 / 14700	14500 / 14800	14400 / 14700
	5.7	Gradeability w. / w.o. load - Efficiency	%	8.1/13.5	7.5/13.5	8.1/13.5	7.1/12.7
		Gradeability w. / w.o. load - Drive&Lift Plus	%	9.4 / 15.8	8.8 / 15.8	9.4 / 15.8	8.4 / 15
	5.8	Max. gradeability, laden/unladen - Efficiency	%	12.5/20.4	12.1/20.0	12.5/20.4	11.4/18.9
		Max. gradeability, laden/unladen - Drive&Lift Plus	%	13.7 / 23.9	13.2 / 23.4	13.7 / 23.4	12.5 / 22.2
5.9	Acceleration time w. / w.o. load - Efficiency	S	5.7/4.8	6.0/5.2	5.7/4.8	6.4/5.5	
	Acceleration time w. / w.o. load - Drive&Lift Plus	S	5.5 / 4.8	5.8 / 5.2	5.5 / 4.8	6.1 / 5.5	
5.10	Service brake	Mechanical					
Electrics	6.1	Drive motor rating S2 60 min.	kW	14.0 / 18.0 ²⁾			
	6.2	Lift motor rating at S3 15%	kW	20.0 / 24.0 ²⁾			
	6.3	Battery according to DIN 43531/35/36 A,B,C, no	A 43536				
	6.4	Battery voltage/nominal capacity K5	V/Ah	80 / 930			
	6.5	Battery weight	kg	2178			
		Battery dimensions L/W/H	mm	1028 / 999 / 784			
6.6	energy consumption according to VDI cycle	kW/h	12.1	12.4	12.4	13.15	
Misc.	8.1	type of drive control	Impuls/AC				
	8.2	working pressure for attachments	bar	200			
	8.3	oil flow for attachments	l/min	30			
	8.4	Sound pressure level at operator's ear according to EN 12053	dB (A)	69			
	8.5	Trailer coupling, model/type DIN	DIN 15170 H				

¹⁾ +31 mm with DZ mast

²⁾ Second value for Drive&Lift Plus package

In accordance with VDI Guideline 2198 this specification sheet provides details of the standard truck only. Non-standard tyres, different masts, optional equipment, etc. may result in different values.

Benefit from the advantages



Pure Energy

Our Pure Energy technology concept enables us to achieve the best possible energy efficiency coupled with maximum performance.

- Most advanced three-phase AC technology.
- Own manufactured electronic controller.
- Compact hydraulic unit.
- Efficient control of the hydraulics/ motors.

Options packages

The right truck for every customer application. The Efficiency and Drive&Lift Plus packages make it possible:

Efficiency Package:

- Curve Control.

Drive&Lift Plus Package:

- Performance package with higher travel/ lift speeds.

Parameter steering

Electric steering with dynamic response dependent on the travel programme selected.

Minimises unwanted steering changes.

- Slim steering column creates more legroom.
- Further improved energy efficiency.
- Further optimised throughput.

Lateral battery replacement with SnapFit

- Universal battery replacement system for all 48 V and 80 V trucks.
- Simple, quick and reliable replacement system.

Ergonomic operator compartment

The ergonomics of the operator's cab guarantees relaxed, fatigue-free work:

- Low entry step height with level footwell.
- Slim steering column for maximum knee and legroom.
- Steering column and armrest can be quickly and intuitively adjusted (single-point adjustment).
- Unobstructed view thanks to special overhead guard design, optimised profile and hose configuration.
- Particularly comfortable operation due to the integration of all controls into the armrest which moves with the operator.
- Limited vibration as the cab is not directly connected to the chassis (floating cab).
- Operator-oriented storage layout.
- Cup holder in two sizes.
- Clipboard.
- Generously proportioned boxes

Safety

High travel speeds and performance levels also require a high level of safety:

- Reduction in travel speed when cornering with Curve Control.
- Easier servicing due to modular component design and very good accessibility.
- Maximum stability due to extremely low centre of gravity and high mounted steer axle.

A range of optional driver assistance systems provide additional safety for the operator, the truck and the load:

- Automatic parking brake ensures there is no uncontrolled operation on ramps and slopes.
- Access Control: The access control system unlocks the vehicle only after a sequence of safety checks:
 1. Valid access code/activation of key switch
 2. Operation of the seat switch (operator in seat)
 3. Seatbelt is secured
- Drive Control: The speed control which automatically reduces the speed of travel when cornering and from a defined lift height.
- Lift Control: The lift speed control which, in addition to the travel speed reduction, also automatically reduces the tilt speed of the mast from a defined lift height. The tilt angle is shown on a separate display.

Jungheinrich UK Ltd.

Head Office:

Sherbourne House

Sherbourne Drive

Tilbrook

Milton Keynes MK7 8HX

Telephone 01908 363100

Fax 01908 363180

info@jungheinrich.co.uk

www.jungheinrich.co.uk

Jungheinrich Plants, Sales and Services Europe ISO 9001/ ISO 14001



Jungheinrich fork lift trucks meet European safety requirements.



JUNGHEINRICH
Machines. Ideas. Solutions.